

Features and Benefits



Product Information

- * Adjustable mushroom cams
- * Simple to Install
- * Available in 20mm and 22mm backset gearbox
- * 62mm robust unhandled die-cast gearbox
- * 8mm and 10mm cam heights
- * Bar sizes from 250mm to 1200mm
- * Profile related keeps with night vent facility

Assessment Data

Performance: BBA Approved.
Tested to 100,000 cycles
Cyclic operation in accordance with BS EN 1191 : 2012
10 year mechanical guarantee
Minimum of 240 hours salt spray testing, exceeding BSEN 1670:2007

Additional Information

Box Qty: 20 per box.



Window & Door Accessories Ltd.

Richmond House, Newtown Avenue, Malahide Road Industrial Park, Dublin 17

Tel: 01-8670011 Fax: 01-8670011 Email: info@wdacc.ie Web: www.wdacc.ie

Technical Drawing

Handle fixing and lockcase routing detail

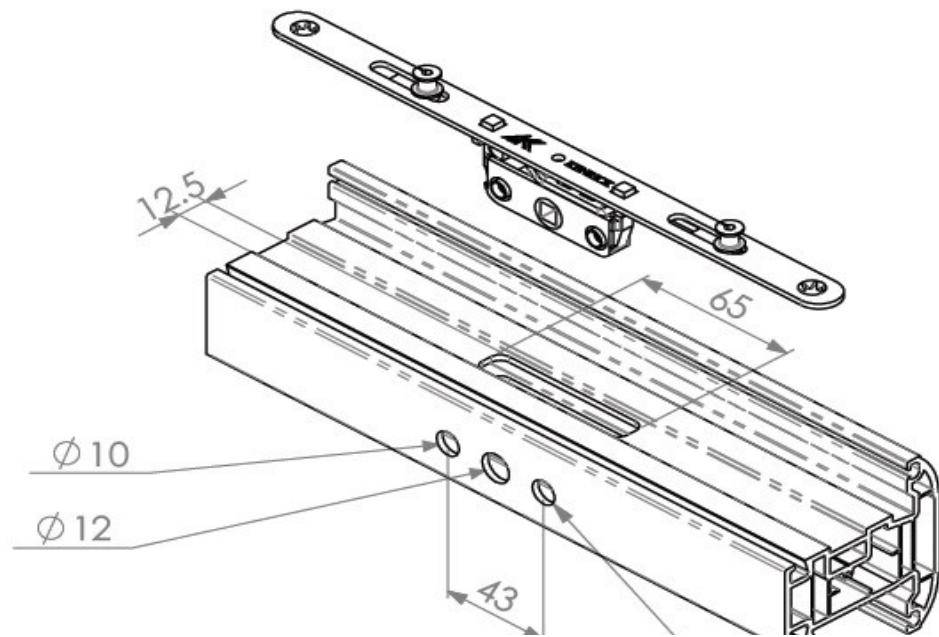

Lockcase dimensions

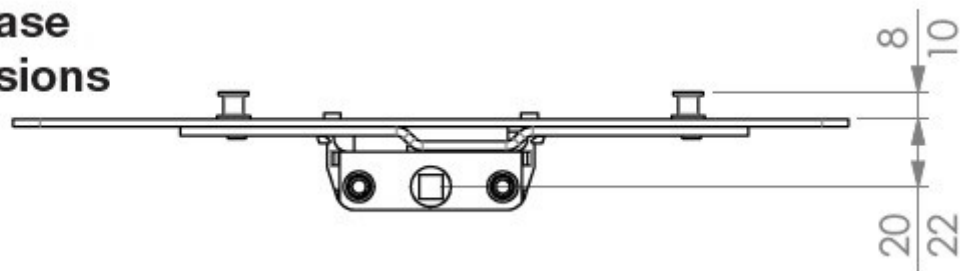

Product Codes

Inline Espag Handle			
Code	Description	Size	Locking Points
A1010-22-250	Single Cam Espag, Cam=10mm	250mm	2
A1010-22-400	Single Cam Espag, Cam=10mm	400mm	2
A1010-22-600	Single Cam Espag, Cam=10mm	600mm	2
A1010-22-800	Single Cam Espag, Cam=10mm	800mm	2
A1010-22-1000	Single Cam Espag, Cam=10mm	1000mm	3
A1010-22-1200	Single Cam Espag, Cam=10mm	1200mm	4

Single Cam Espag



Window & Door Accessories Ltd.

Richmond House, Newtown Avenue, Malahide Road Industrial Park, Dublin 17

Tel: 01-8670011 Fax: 01-8670011 Email: info@wdacc.ie Web: www.wdacc.ie